

- Stores 5 separate 3-point (high-mid-low) calibration tables for multiple products

- Complete Digital Processing provides push button, drift-free calibration

- Nonvolatile Battery Backed Memory for safe storage of calibration data

- Many types of digital outputs available

- LED display provides direct read-out in percent moisture content

- The console enclosure provides a touch key board and detailed operating legend for easy data entry

- Optional Security Pass Code prevents unauthorized access to the calibration data

- Loss of Product detection shows when there is no product under sensor

- Analog output provides standard 4-20mA output proportional to moisture for interfacing to industrial control systems

- Programmable Alarm Solid State Relays assure warning alarm when moisture set point is reached or Loss of Product occurs

- Sample-on-Command feature provides for gated readings of batch operations

- Programmable Smoothing Function reduces undesired output fluctuations by averaging readings

- For Continuous On-Line Analysis, PID Closed Loop Feed-back Control, or in the Lab for Static Testing

- A System consists of three components: the BSP-901 Wall Mounted Console and a NIR Sensor with a power box or a RF Sensor with an Oscillator Box

Model BSP-901 Moisture Analysis System

BSP-901 NIR System

- Nondestructive moisture sensing from 0 to 80%
- Filtration of reflected energy from sample reduces ambient light and color considerations
- Simplified optics, no mirror or lenses to align
- Stable quartz halogen NIR sensor
- Drift-free temperature stability
- Auto Ranging is used to adjust the NIR Sensor output to an optimum level for reliable processing
- For Flat Belt Conveyors, Static Samples, Moving Webs, Screw Conveyors, Hopper-Drop Chutes, Pneumatic Lines

The BSP-901 NIR System uses the principle of comparing energy at two near infrared wavelengths to determine moisture on a continuous basis. A stabilized infrared source is focused on the material to be measured and reflected light is filtered at two different wavelengths, one specific for moisture and the other a reference wavelength. The two signals are electronically ratioed and the moisture content is presented on the digital display. The non-contact NIR technique measures near surface moisture in a wide range of applications.



BSP-901 Console



NIR Sensor

BSP-901 RF System

The BSP-901 RF Sensor employs a radio frequency (RF) power loss technique that operates at 2 Megahertz. The Sensor projects an RF field into the sample and measures the loss or change in RF dielectric constant as affected by moisture. Thus, the System response is a measure of the total water in the RF field, which is directly related to the moisture content of the material.

For high temperature environments up to 485°F (250°C), the high temperature RF sensor can detect product moistures inside a kiln or dryer. Its unique open frame construction minimizes dirt and contaminant accumulations.

RF Sensors

- 3" x 48" Open Frame High Temp
- 4" x 36" & 6" x 8" Box Sensor
- 3" x 18" Open Frame Sensor
- Special Low or High Temp Sensors
- Shallow Penetration Depths Available

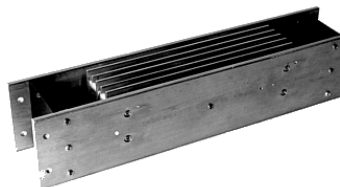

3"x18" RF Sensor

RF Probe

The RF Probe is ideal for powdered and granular materials in chutes, bins, silos, conveyor belts, or statically in buckets. The RF Probe is most effective on products that have constant density and sufficient volume to absorb the 3" diameter RF field emitted from the end of the probe. The RF probes can be provided from 6" to 48" in length and are available for high and low temperatures.



www.MoistureRegisterProducts.com

George R. Peters Associates ENGINEERING SALES REPRESENTATIVES

(248) 524-2211 • Fax (248) 524-1758

Web Site: www.grpeters.com

Console Specifications	
Moisture Range	0 to 80 percent
Accuracy	± 0.02% to 0.2% depending on product and moisture range being measured
Repeatability	± 0.01% depending on application
Instrument Stability	Better than 1 part in 1,000
Update Rate	7 moisture calculations per second
Ambient Operating Temperature	0 to 50°C
Relative Humidity	0 to 90 percent non-condensing
Storage Temperature	-18 to 80°C
Dimensions	12"H x 10½"W x 5"D (30.48cm x 26.67cm x 12.70cm)
Power Requirements	120 VAC ± 10% 60 HZ or 230 VAC ± 10% 50 HZ
Inputs	NIR or RF Sensor; Sample on Command (Auto or Manual Select)
Outputs	4 to 20 mA (Moisture or PID Control) · Programmable Hi-Lo Alarm Contacts · Loss of Product Alarm · Blower Control (for Opto-Port)

NIR Sensor Specifications	
Operating Temperature	Max: 122°F/50°C Minimum: 30°F/0°C
Storage Temperature	Max: 176°F/80°C Minimum: 0°F/-18°C
Lens Distance to Product	9" (228mm) ± 1" (25mm)
Dimensions & Weight	14½" x 10½" x 5.375" (368mm x 266.7mm x 137mm); 13½ lbs. (6.1 kg)

NIR Sensor Optional Features	
Opto-Port Attachment	Allows sensor to adapt to a variety of difficult sample handling situations such as screw conveyors and free fall conveyors
Explosion Proof Housing	Call for a quote.
Remote Operator and Software	Displays moisture reading on a PC. Provides for multiple calibration files to be stored/downloaded.
Low Profile NIR Optical Attachment	Allows sensor to be mounted at locations where the clearance is a consideration

Additional features are available. Call for further details.

Targeting the Solution with Innovation and Quality

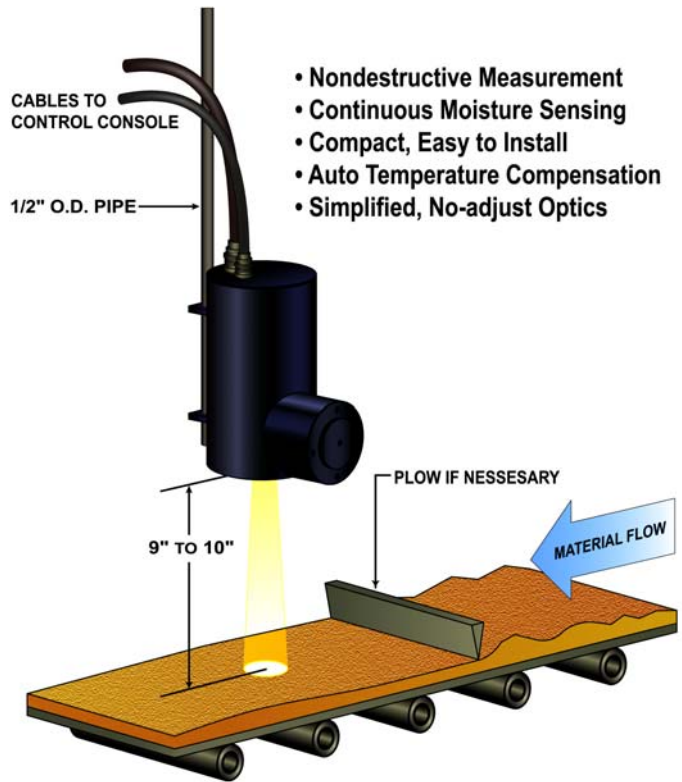

- Nondestructive Measurement
- Continuous Moisture Sensing
- Compact, Easy to Install
- Auto Temperature Compensation
- Simplified, No-adjust Optics

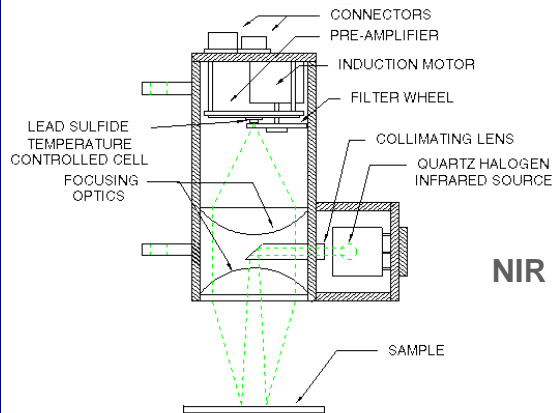

NIR Sensor

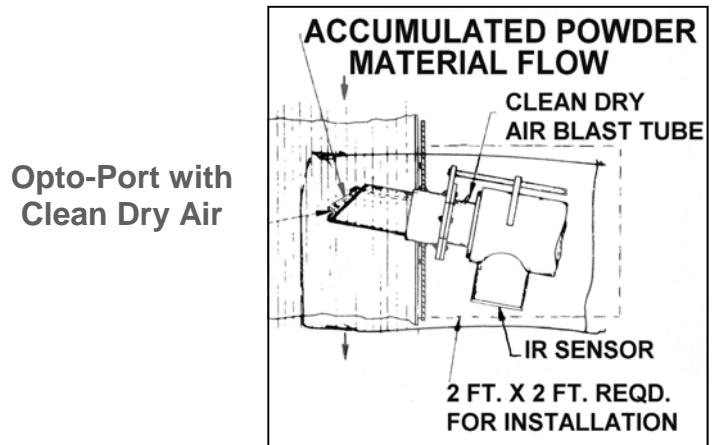

Opto-Port with Clean Dry Air



Moisture Register Products

a division of AQUA Measure Instrument Co.
1712 Earhart Court • La Verne, CA 91750 • USA
(909)392-5833 • (800)966-4788 • Fax (909)392-5838
www.MoistureRegisterProducts.com • sales@aquameasure.com

George R. Peters Associates ENGINEERING SALES REPRESENTATIVES

(248) 524-2211 • Fax (248) 524-1758

Web Site: www.grpeters.com